

Step_Motor / PLC_1 [CPU 1212C AC/DC/Rly] / Blocchi di programma

Blocco_1 [FC1]

Blocco_1 Proprietà

Generale

Nome	Blocco_1	Numero	1	Tipo	FC	Linguaggio	KOP
Numerazione	Automatico						

Informazioni

Titolo		Autore		Commento		Famiglia	
Versione	0.1	ID definito dall'utente					

Blocco_1

Nome	Tipo di dati	Valore di default	Commento
Input			
Output			
InOut			
Temp			
Constant			
▼ Return			
Blocco_1	Void		

Segmento 2:

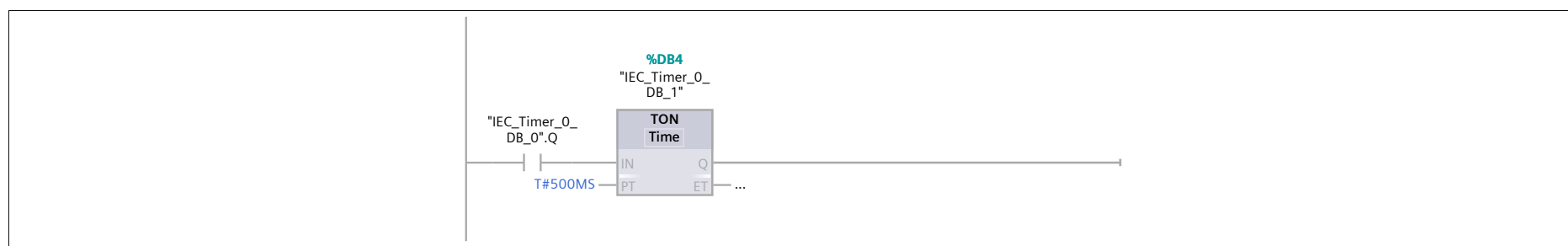

Simbolo	Indirizzo	Tipo	Commento
"IEC_Timer_0_DB_0".Q		Bool	

Segmento 3:

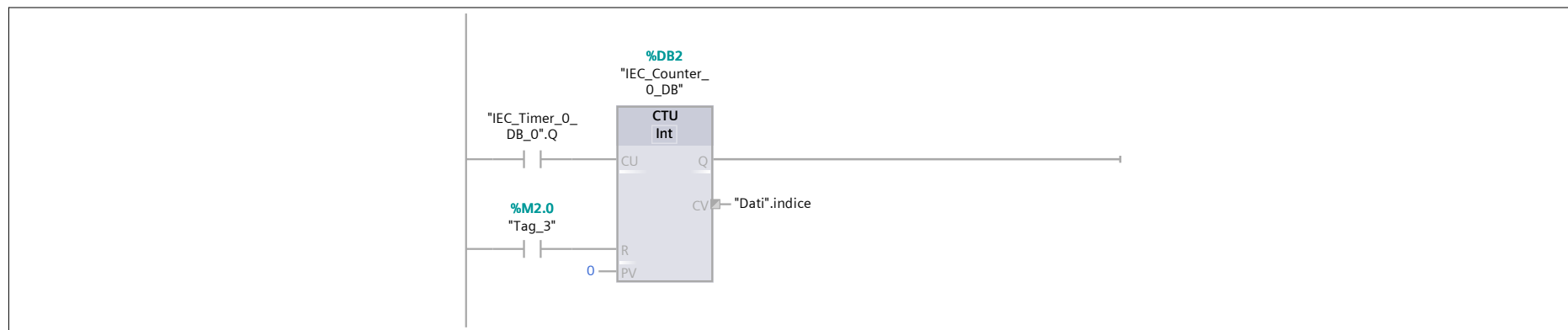

Simbolo	Indirizzo	Tipo	Commento
"Dati".indice		DInt	
"IEC_Timer_0_DB_0".Q		Bool	
"Tag_3"	%M2.0	Bool	

Segmento 1:

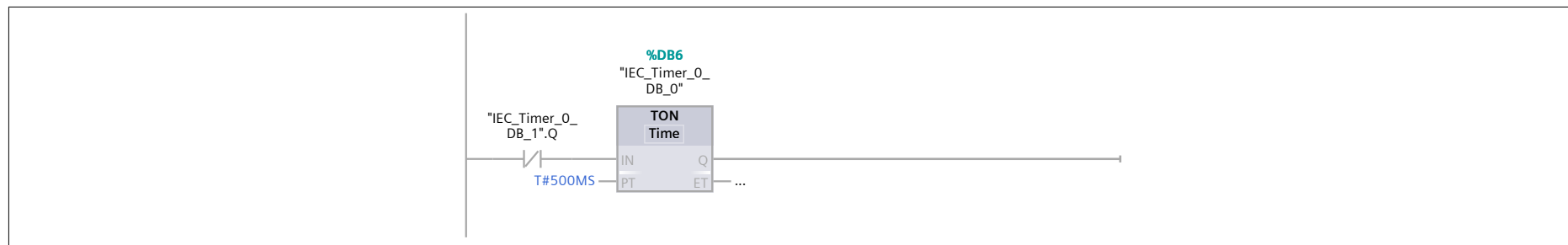

Simbolo	Indirizzo	Tipo	Commento
"IEC_Timer_0_DB_1".Q		Bool	

Segmento 4:

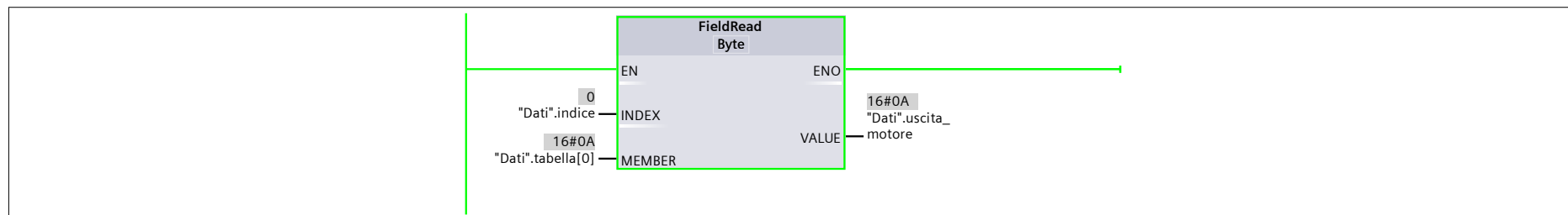

Simbolo	Indirizzo	Tipo	Commento
"Dati".indice		DInt	
"Dati".tabella[0]		Byte	
"Dati".uscita_motore		Byte	

Segmento 6:

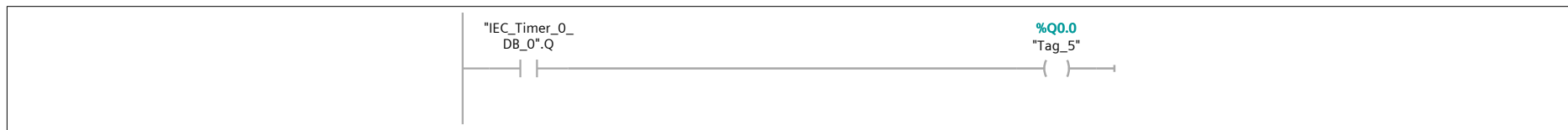

Simbolo	Indirizzo	Tipo	Commento
"IEC_Timer_0_DB_0".Q		Bool	
"Tag_5"	%Q0.0	Bool	

Segmento 5:

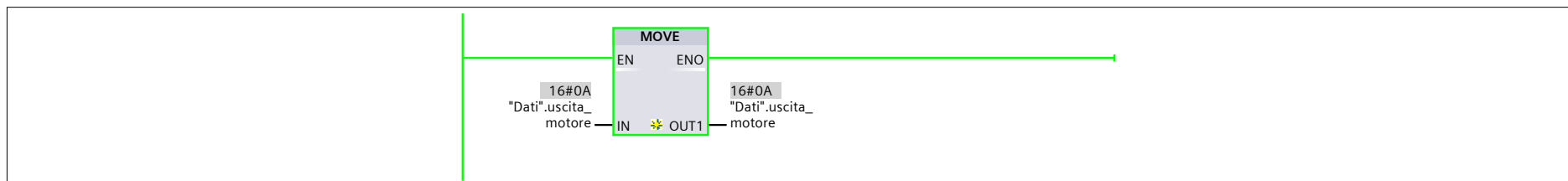

Simbolo	Indirizzo	Tipo	Commento
"Dati".uscita_motore		Byte	