

FC1 - <offline>

" "
Nome: Famiglia:
Autore: Versione: 0.1
Versione blocco: 2
Data e ora Codice: 21/10/2015 22.54.13
Interfaccia: 12/10/2015 20.32.34
Lunghezze (blocco / codice / dati): 00996 00798 00006

Nome	Tipo di dati	Indirizzo	Commento
IN		0.0	
OUT		0.0	
IN_OUT		0.0	
TEMP		0.0	
RETURN		0.0	
RET_VAL		0.0	

Blocco: FC1

Segmento: 1 Richiamo DB1



Segmento: 2 Fronte di salita bottone +5

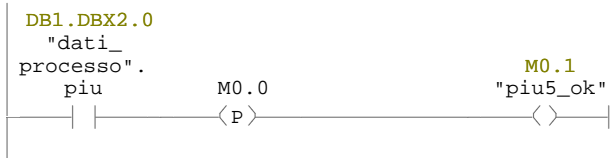

Segmento: 3 Sommatore bottone +5

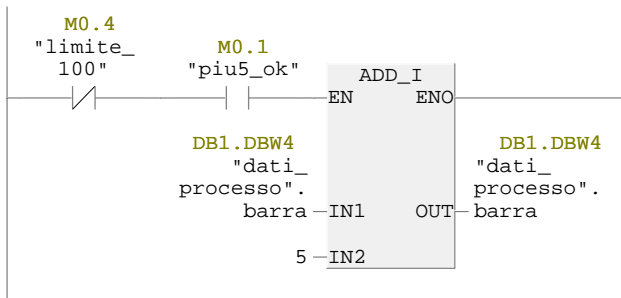

Segmento: 4 Fronte di salita bottone -5

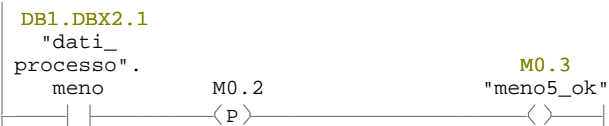

Segmento: 5 Sottrattore bottone -5

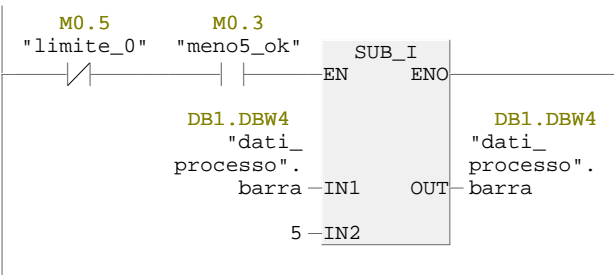

Segmento: 6 Limite barra massimo

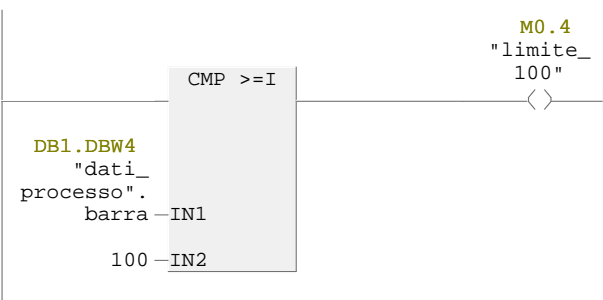

Segmento: 7 Limite barra minimo

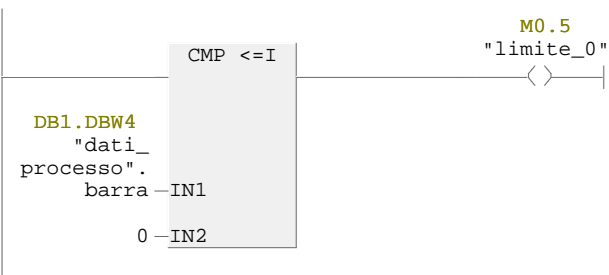

Segmento: 8 "Inversione" della percentuale

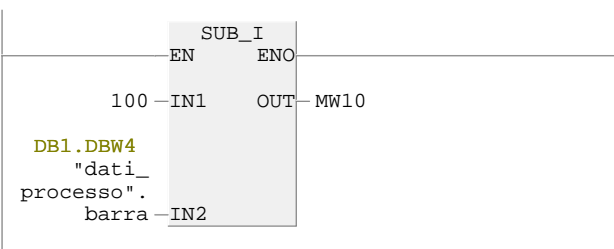

Segmento: 9 Conversione nuova percentuale in double word

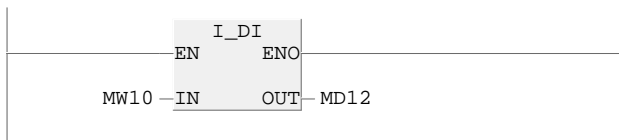

Segmento: 10 Conversione nuova percentuale in real

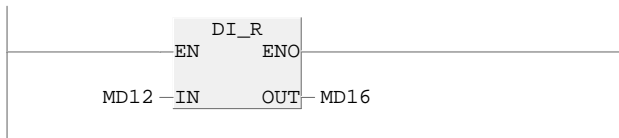

Segmento: 11 Carica il valore "100"

```

L    100
T    MW    20
L    MW    20
ITD
T    MD    22
L    MD    22
DTR
T    MD    26
  
```

Segmento: 12 Carica il valore del moltiplicatore

```

L    "dati_processo".moltiplicatore DB1.DBW12
T    MW    30
L    MW    30
ITD
T    MD    32
L    MD    32
DTR
T    MD    36
  
```

Segmento: 13 Trasforma la percentuale in numero razionale

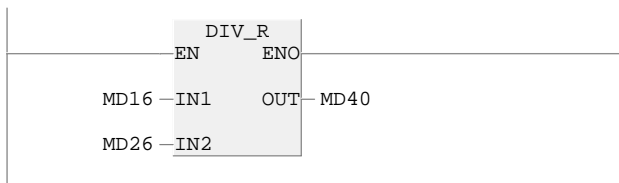

Segmento: 14 Moltiplica il numero razionale per il moltiplicatore

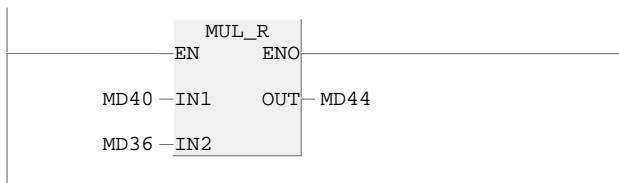

Segmento: 15 Arrotonda il valore del semiperiodo

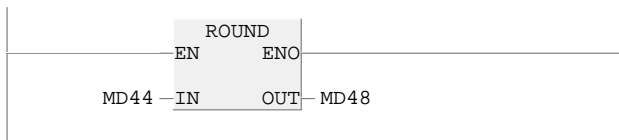

Segmento: 16 Trasforma il semiperiodo da double word a S5time

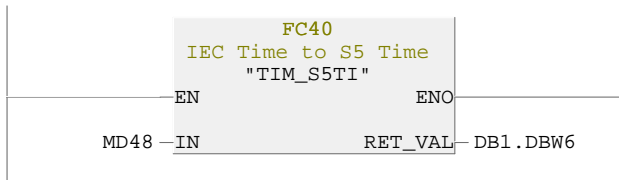

Segmento: 17 Timer per far girare lo stepper (1)

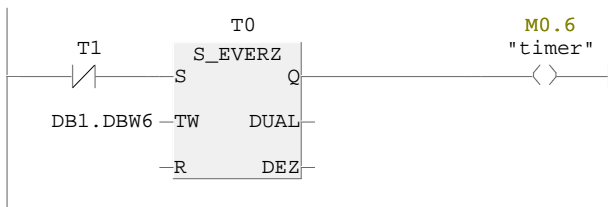

Segmento: 18 Timer per far girare lo stepper (2)

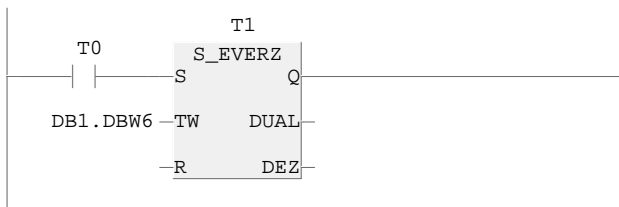

Segmento: 19 Fronte di salita del timer

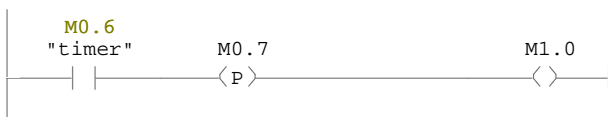

Segmento: 20 Contatore in avanti per creare la tabella dello stepper

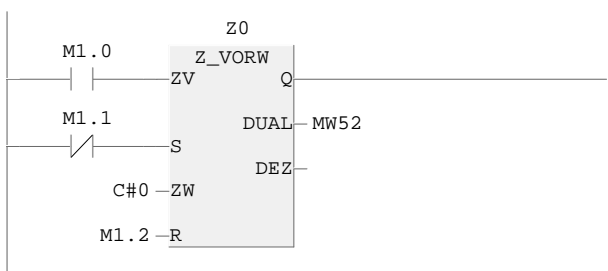

Segmento: 21 Reset contatore

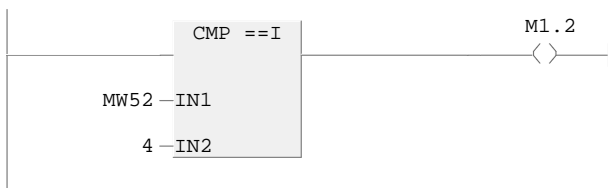

Segmento: 22 Prima riga tabella stepper

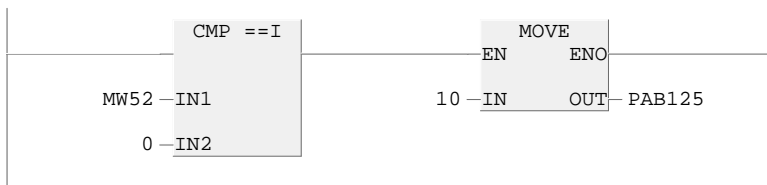

Segmento: 23 Seconda riga tabella stepper

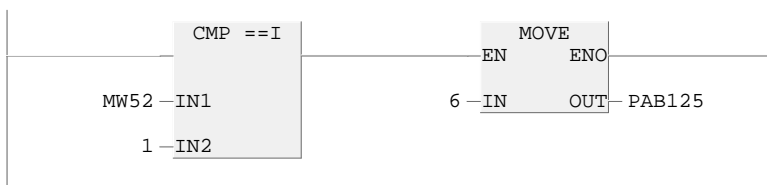

Segmento: 24 Terza riga tabella stepper

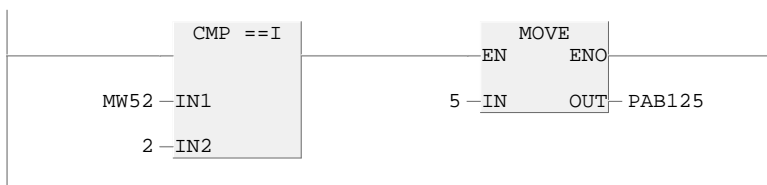

Segmento: 25 Quarta riga tabella stepper

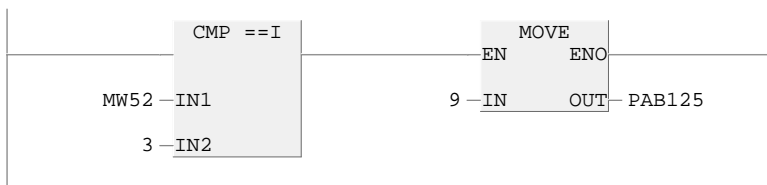

Segmento: 26 Fronte salita anti rimbalzo proximity

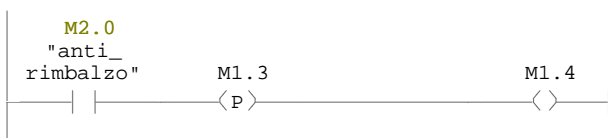

Segmento: 27 Anti rimbalzo per evitare sfarfallio proximity

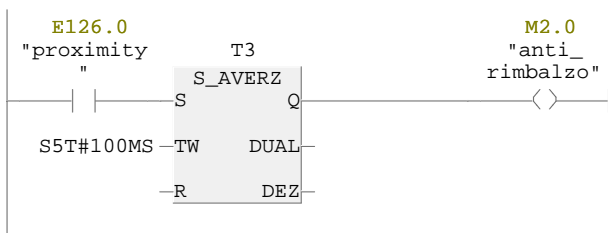

Segmento: 28 Contatore in avanti proximity

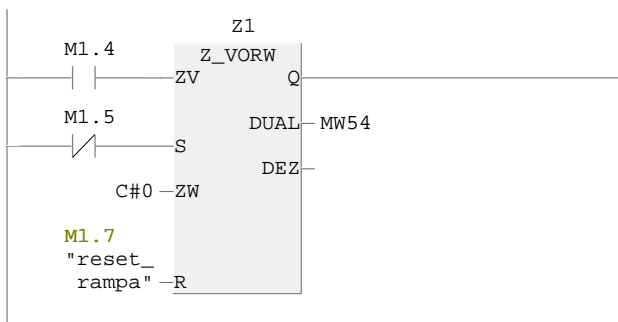

Segmento: 29 Set rampa proximity

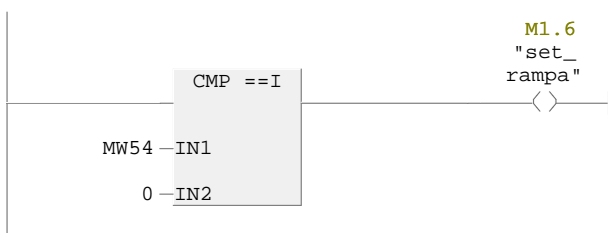

Segmento: 30 Reset rampa proximity

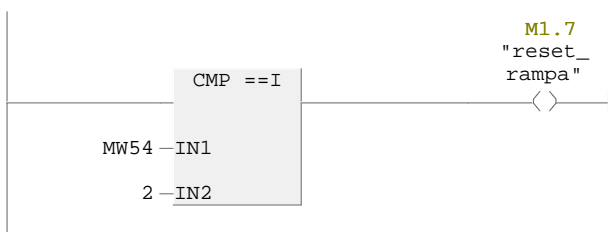

Segmento: 31 Rampa proximity

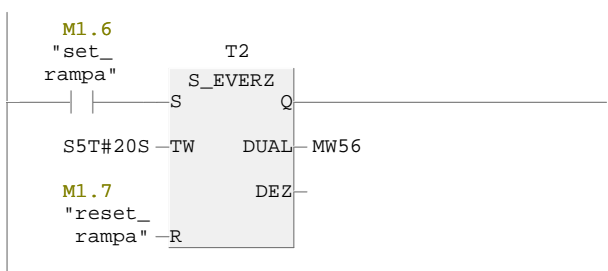

Segmento: 32 Trasferimento valore massimo raggiunto dalla rampa

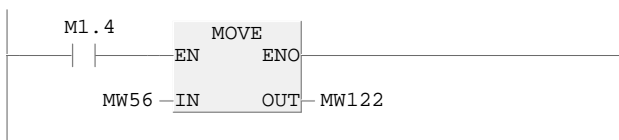

Segmento: 33 Conversione valore massimo in decimale

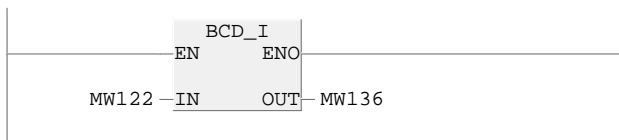

Segmento: 34 Conversione valore massimo in double word

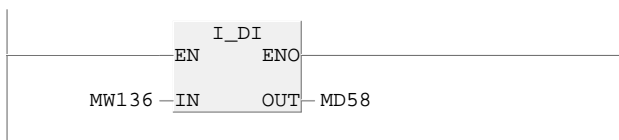

Segmento: 35 Conversione valore massimo in real

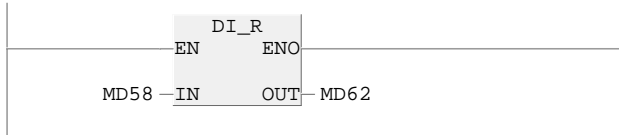

Segmento: 36 Caricamento numero alette encoder (5)

L	5	
T	MW	66
L	MW	66
ITD		
T	MD	68
L	MD	68
DTR		
T	MD	72

Segmento: 37 Calcolo periodo

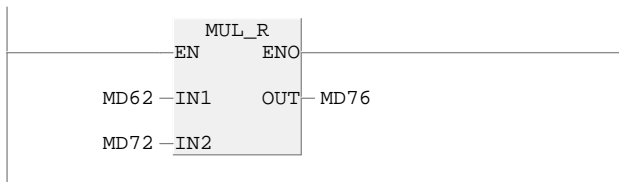

Segmento: 38 Caricamento valore 1

```

L      1
T      MW      80
L      MW      80
ITD
T      MD      82
L      MD      82
DTR
T      MD      86

```

Segmento: 39 Calcolo frequenza

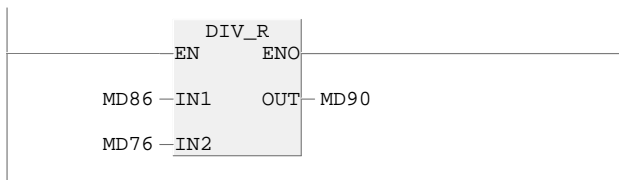

Segmento: 40 Caricamento valore 2*pigreco

```

L      6.283185e+000
T      MW      94
L      MW      94
ITD
T      MD      96
L      MD      96
DTR
T      MD      100

```

Segmento: 41 Calcolo velocità angolare

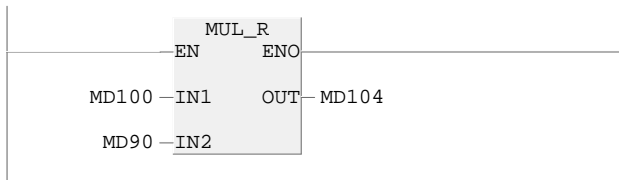

Segmento: 42 Caricamento valore raggio motore stepper (0.1)

```

L      1.000000e-001
T      MW      108
L      MW      108
ITD
T      MD      110
L      MD      110
DTR
T      MD      114

```

Segmento: 43 Calcolo velocità tangenziale

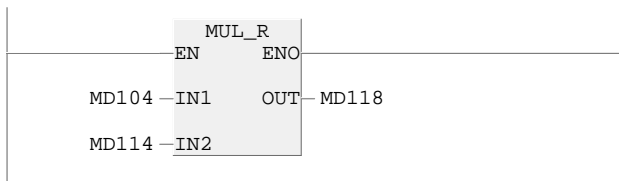

Segmento: 44 Frequenzimetro

Usa come ingresso A126.0 e come abilitazione un merker negato su "EN". Vi sono poi altre due abilitazioni (M2.1 e M2.2) per i valori limite. L'uscita, infine,

viene restituita su una double word.

